



1225 NORTH LOOP WEST, SUITE 935, HOUSTON, TX 77008
(713)864-8494
WWW.ACICO.COM

September 18, 2017

Matt Ogden
Evolution Dog Wash

Re: ADA Compliance

Dear Mr. Ogden,

You requested that I review the design of the Evolution Dog Wash system for compliance with the Americans with Disabilities Act (ADA) and Fair Housing Act. The purpose of this letter is to describe how the features of this system comply with the requirements of the ADA/FHA and to identify installation issues that must be considered to ensure compliance.

Applicability of the ADA and FHA

Title III of the ADA states that individuals with disabilities are entitled to equal enjoyment of the goods and services of a public accommodation. Public accommodations include businesses that provide goods and services to the public.

Title II of the ADA requires that programs offered by State & Local Governments be made available to people with disabilities.

The Fair Housing Act includes design requirements for the construction of multi-family housing. These design requirements require that at least one of each type of amenity offered must be accessible. The dimensional requirements for the FHA are equivalent to the ADA Standards.

If the Evolution Dog Wash is made available for public use on either private or public property it will be required to comply with either the ADA or FHA.

Dimensional Requirements

The ADA and FHA have equivalent requirements. The following relevant sections are excerpted from the 2010 ADA Standards.

The Evolution Dog Wash system has been designed to comply with the following requirements for reach range to operable parts. All controls necessary for normal operation including buttons, coin slots, soap dispensers, water hoses and blower hose are within the 48" high maximum reach range for an unobstructed side approach. With the gate closed, the water hose and blower hose are within the 46" maximum high reach range for an obstructed side approach.

308.3.1 Unobstructed. Where a clear floor or ground space allows a parallel approach to an element and the side reach is unobstructed, the high side reach shall be 48 inches (1220 mm) maximum and the low side reach shall be 15 inches (380 mm) minimum above the finish floor or ground.

308.3.2 Obstructed High Reach. Where a clear floor or ground space allows a parallel approach to an element and the high side reach is over an obstruction, the height of the obstruction shall be 34 inches (865 mm) maximum and the depth of the obstruction shall be 24 inches (610 mm) maximum. The high side reach shall be 48 inches (1220 mm) maximum for a reach depth of 10 inches (255 mm) maximum. Where the reach depth exceeds 10 inches (255 mm), the high side reach shall be 46 inches (1170 mm) maximum for a reach depth of 24 inches (610 mm) maximum.

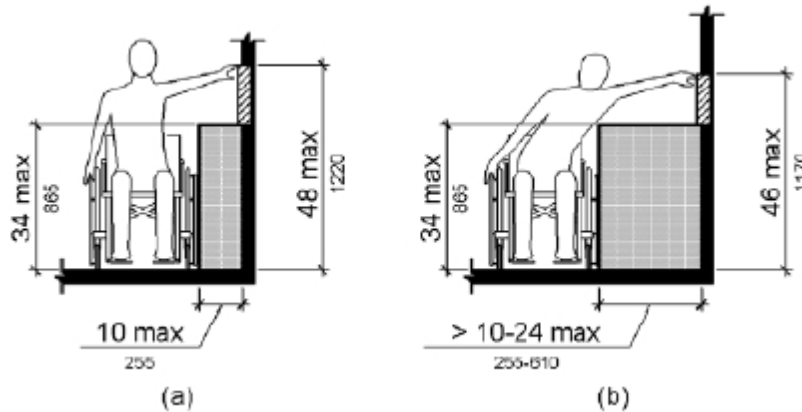

The controls on the Evolution Dog Wash system comply with the requirements for operable parts and do not include tight grasping, pinching or twisting of the wrist to operate.

309.4 Operation. Operable parts shall be operable with one hand and shall not require tight grasping, pinching, or twisting of the wrist. The force required to activate operable parts shall be 5 pounds (22.2 N) maximum.

The Evolution Dog Wash system must be located in an accessible location that is accessed by a 36" wide minimum accessible route. A clear floor space the full width and 30" deep measured perpendicular to the appliance shall be provided. This floor space shall not have slopes greater than 1/4" per foot. The floor surface must be firm, stable and slip resistant. Gravel and grass areas are not recommended.

302.1 General. Floor and ground surfaces shall be stable, firm, and slip resistant and shall comply with 302.

305.2 Floor or Ground Surfaces. Floor or ground surfaces of a clear floor or ground space shall comply with 302. Changes in level are not permitted. EXCEPTION: Slopes not steeper than 1:48 shall be permitted.

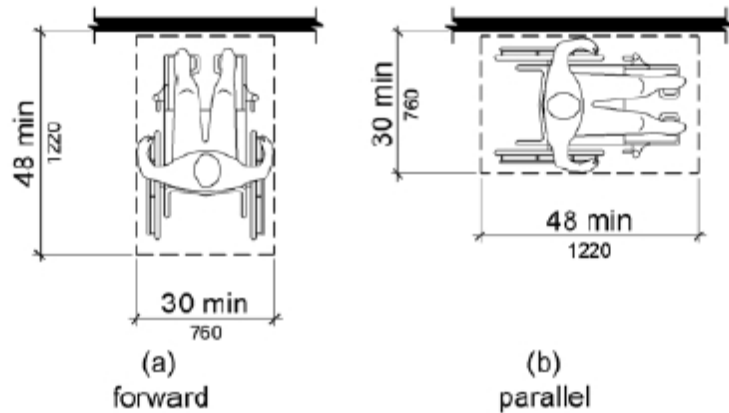

The Evolution Dog Wash has been designed to be usable and accessible to all. This equipment complies with the intent of the ADA to provide equal enjoyment of goods and services to people with disabilities.

Please call if you have any questions.

Sincerely yours,

AMERICAN CONSTRUCTION INVESTIGATIONS, LTD.

Jeremy G. Murphy, AIA, RAS
Director, Accessibility & Code Consulting Services